

HYDRAULIC PALLET TRUCK

Capacity : 2000 kg.

TECHNICAL SPECIFICATIONS

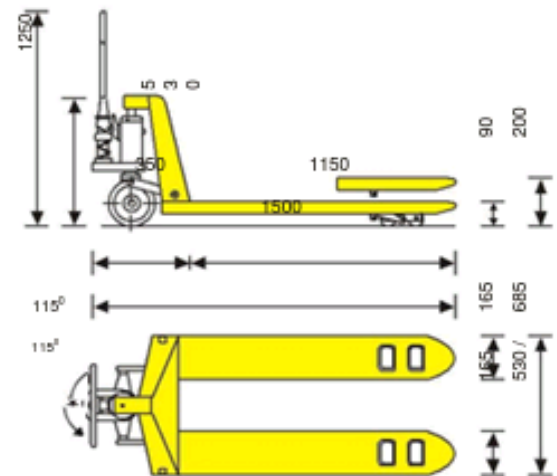
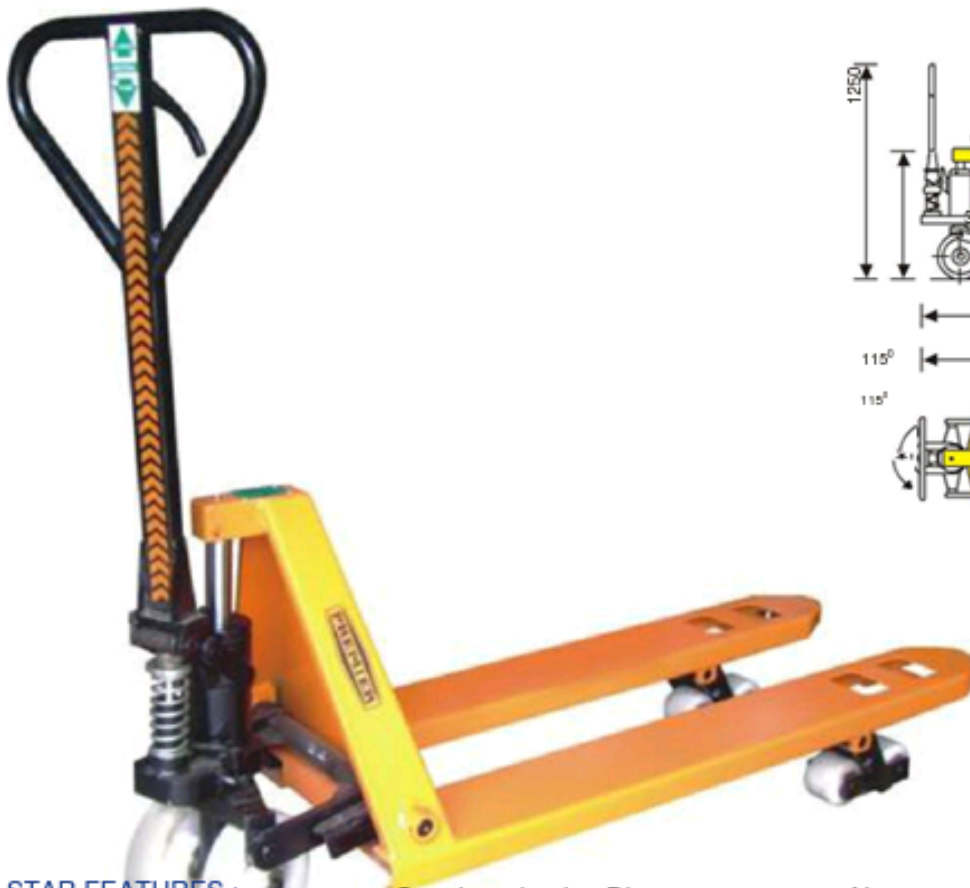

Paper Roll Lifting with Taper Fork Pallet Truck



STAR FEATURES :

- Robust in Construction
- Powder Coated Body
- Easy to Operate
- Silent in Operations
- Easy Pallet Entry and Exit

- Steering wheels - Dia 200 x 50 mm - 2 Nos.
- Forks wheels - Dia 82 x 70 mm - 4 Nos. (Tandem Rollers)
- Truck weight - 90 kg.
- Load Capacity - 2000 kg. (Uniformly distributed on forks over 1 x 1 mtr. Pallet)

- AN IDEAL EQUIPMENT FOR ALL TYPES OF INDUSTRIES.
- WE ALSO MAKE CUSTOM BUILT PALLET TRUCKS AS PER CUSTOMER'S REQUIREMENTS.



TANDEM ROLLERS WITH CLIMBER WHEELS



EXCELLENT MANOEUVERABILITY DIA 200 MM STEERING WHEELS



ERGONOMIC HANDLE WITH THREE POSITION LEVER



SPECIALLY DESIGNED FORKS TO AVOID WEAKER SECTION AT END



ALL PIVOTED JOINTS ARE WITH PHOSPHOR BRONZE BUSHING



RELIABLE HYDRAULIC SYSTEM SINGLE CARTRIDGE VALVE



POLYMER WHEELS WITH SEALED BALL BEARINGS
PU WHEELS



CUSTOM BUILT PALLET TRUCKS FORK LENGTH UPTO 2200 MM WIDTH UPTO 685 MM